





KC Winch
Model 40.250 – 30 kW

Manual

KC Denmark A/S

Research Equipment
Limnology • Oceanography • Hydrobiology

	<p align="center">Manual for Winch, 30 kW</p>	<p align="center">Model no. 40.250</p>
	<p align="center">  Caution This winch is very dangerous in unskilled hands and serious precautions must be taken to avoid accidents. </p> <p> The safety cover must always be in the secured position to avoid any contact with the drum and the wire during operation. </p> <p> KC Denmark A/S is not, and cannot be held, responsible for any damage(s) made to equipment or to operators who ignore safety precautions or because of misuse or wrong operation. </p> <p> Before operating the winch for the first time, always check the lubricant level for the gear box, see item #9. </p>	
	<p>Preparation:</p>	
<p>1</p>	<p>The winch has 4 additional stands; they must be removed before installing. The winch must be secured on a plain and stable surface before use.</p> <p>Fasten with 4 bolts. To avoid any damage or injury, you must ensure free space for the wire in all positions.</p>	
<p>2</p>	<p>The rack for the brake resistors is placed next to the winch. Secure the connector to the winch. The brake resistor must be placed on a well ventilated place and protected from rain and humidity.</p> <p>The rack must be connected properly, otherwise the winch isn't operational.</p>	

Operating the winch

Ensure the proper power supply is available.

Standard delivery demands 3 x 400 V AC/50 Hz + ground. Optional 3 x 500 V AC/60 Hz.

- 3 Faulty connection or voltage may damage the winch and void the warranty.

Power supply is connected to the EEC plug and turning the switch clockwise will turn on the power.



Caution



- 4 The winch has a total of 3 emergency stops, located at each end of the winch and the last one can be found on the handheld control box. Pushing one of the stops will activate the winch's brake system immediately.



Caution

- 5 **Loosen the mechanical emergency break before use by turning anti clockwise until it stops.** Otherwise, you might cause serious damage to the winch.



6	<ol style="list-style-type: none"> 1. The main switch is turned clockwise to position 1. See item 3 for location of the switch. 2. Press the green "Activate" button. 3. The joystick controls the wire direction and the speed of the winch. The more you press the higher speed. 	
7	<p> Caution</p> <p>When changing direction of the wire, return the joystick to neutral position. It is very important the drum has stopped before you activate the joystick in the opposite direction.</p> <p>By emergency or in need of a fast stop press the emergency switch and the winch will stop immediately. Two emergency switches are located on the winch, one switch at each end.</p>	

Meter and speed counter

Standard delivery of the winch does not include a counter. Adding a counter demands a meter wheel, too. A standard counter will count the meter length with a resolution of 10 cm. Optionally it can be replaced by a 2-display counter measuring the length as well as the speed of the wire.

Power supply:

The counter needs an external power supply of 10 – 24 V AC or DC. Power consumption: Max. 200 mA. Upon request it can be delivered with built-in batteries, power supply or charger.

Connection for power supply:

Brown and blue wire: 10 – 24 V AC or DC.
No need for polarity. Yellow/green wire: Earth.
No needs for connecting to ground.

Before inserting the cable on the meter wheel check out the counting direction of the wheel by manually turning of wheel.

Connection for meter wheel:

Attach the Subconn connector to the meter wheel.

8

Operation:

Push the green button to start the counter and the night visibility.

When you lower the equipment and it hits the sea level, you can reset the counter to zero by pushing the red button.

The display:

The display will show the cable length with a resolution of 10 cm. Built-in light for night visibility and for easy read-out even in strong sun light.

The digits:

The very first digit will show a maximum of 3 bars. The upper and lower bar indicates the counting impulses and at the middle the bar will show the power supply has been connected.

Heating element:

The counter has an internal heating element to prevent condensate water. (Always connected, regardless of the position of the green button).

Interface:

The counter can be equipped with various interfaces for RS-232, RS-485 or for USB. On request, special software can be offered.



Maintenance

The ball bearing must be greased at the least every 6 months.

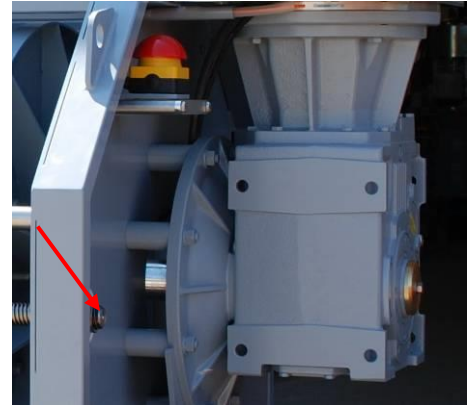

The ball bearing must be greased at the least every 6 months.

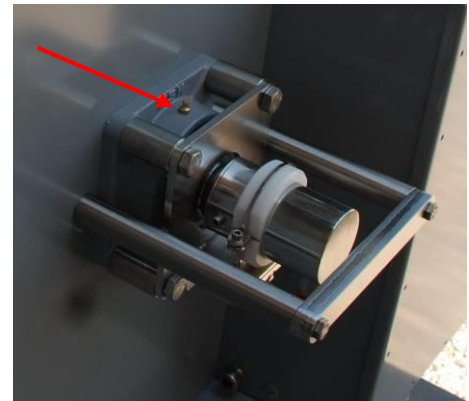

9

For the gearbox the lubricant oil must be checked periodically. Check that the correct level has been reached via the sight glass. Max. 50 % visible through the glass. Top up as necessary. Do not overfill; it will cause excessive heat and potential damage to the gear.

Recommended lubricants or equivalent types:

BP Energol GR-XP 220
Shell Omala 220



The spindle and the guiding system must be greased as needed.



Safety information



Caution

Disconnect power supply to avoid any unattended operation causing accident to personnel and winch.

All maintenance, inspection and repairs must only be done by an expert maintenance technician fully familiar with the attendant hazards.

10

Persons charged with working on the winch and the accessories must be trained specially for the purpose with special abilities and experience in this area as well as being equipped with the appropriate tools and individual safety equipment. Failure to meet these requirements constitutes a risk to personal health and safety and economic damages.

When working on the unit in areas which are difficult to access or hazardous, ensure that adequate safety precautions have been taken for the operator and others in compliance with the provisions of law on health and safety at work.

Replace worn component with original spare parts. Use the lubricants (oil and grease) recommended by the manufacturer.

Technical data for winch 40.250

Item	Details
Electrical:	
Supply	3 x 400 V AC/50 Hz. Optional: 3 x 500 V AC/60 Hz
	Rev. 1440/min
Speed regulation	Regulated by a frequency converter, ABB, 30 kW.
Control box:	AISI 304 stainless steel, 3 mm Enclosure rating: IP 65
Control box:	AISI 304 stainless steel, Enclosure rating: IP 65
Emergency brakes: Total qty: 3 pcs:	1 pc at each end of the winch + 1 brake on the control box,
Motor	
Main motor:	Bonfiglioli 30 kW, with electro magnetic brake, 3 x 400 V AC/50 Hz. Rev. 1440/min.
Gear motor for cable guiding system:	Bonfiglioli, 24 V DC/200 W. Rev. 1500/min. Worm gear, Bonfiglioli MVF 49, Ratio 18:1.
Mechanical:	
Material:	AISI 304 Stainless steel
Main rack:	Square tube, 100 x 100 x 4 mm, AISI 304 stainless steel.
Side plates:	Steel plate, 8 mm, AISI 304 stainless steel. Reinforced with tubes, AISI 304 stainless steel, 60 x 40 x 3 mm.
Drum and disc brake:	8 mm AISI 304 stainless steel
Finish:	The drum and the disc brake: Electro polish Main rack: Painting RAL 5010.
Drum:	Outer diameter: 960 mm Inner diameter: Standard delivery: 460 mm.
Drum rev.:	0 – 84 rev./min. Adjustable
Drum capacity:	3000 m of Ø11,43 mm conductor wire.
Wire speed	Approx. max. 2,5 m/sec.
Angle-gearbox:	Bonfiglioli, type A703 - 5000 Nm Ratio 16,7:1 Limit: 3600 Nm/84 rev./min.
Tractive force:	Inner layer, 460 mm: (Empty drum) kg 940 mm: (Full drum) kg
Brake system 1:	DC brake motor
Brake system 2:	Disc brake (operated by hand), made of 8 mm AISI 316 stainless steel.
Ball bearings:	AISI 304 stainless steel flange ball bearings, 3 pcs Ø30 mm.
Protection shield:	Transparent Polycarbonate, 6 mm
Weight, standard without wire, approx.	1000 kg

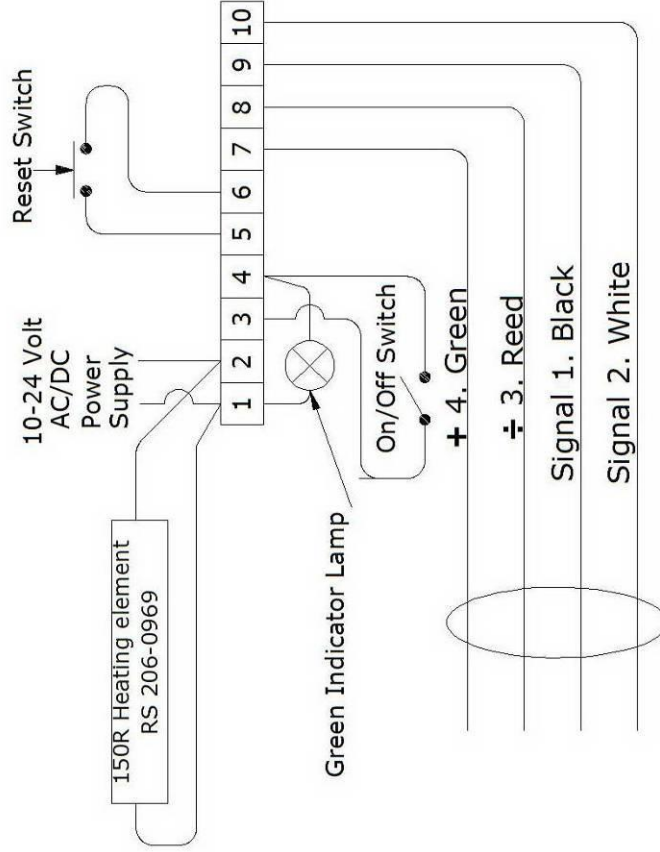
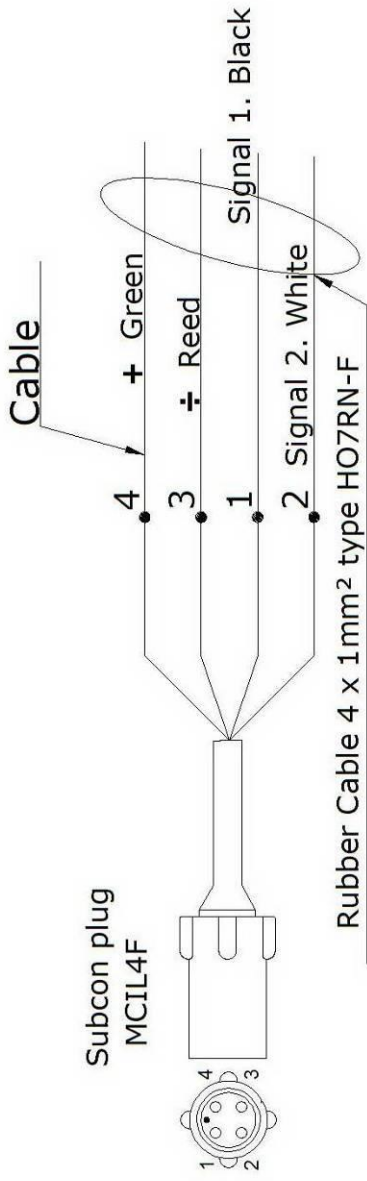

- Colour code for
MCIL4F cable
1. Black wire signal 1
 2. White wire signal 2
 3. Reed wire ÷ 3
 4. Green wire + 4

5 or 10 Meter Subconn Connector Cable MCIL4F
from MacArtney Esbjerg
+45 76 13 20 00

Dato 5-12-2006

KC Denmark - Research Equipment
Lungology, Oxygeography, Physiology
Tel. +45 86 82 83 47 . Fax. +45 86 82 48 00

KC

Connection diagram for
Meter Counter and Wheel

30.363

Kabel til Display boksen

Gummikabel 4 x 1mm² Type HO7RN-F

Farvekode på anvendte
Kabel ledninger.

1. Sort til signal 1
2. Brun til signal 2
3. Blå til plus ÷ 3
4. Grøn/Gul til + 4

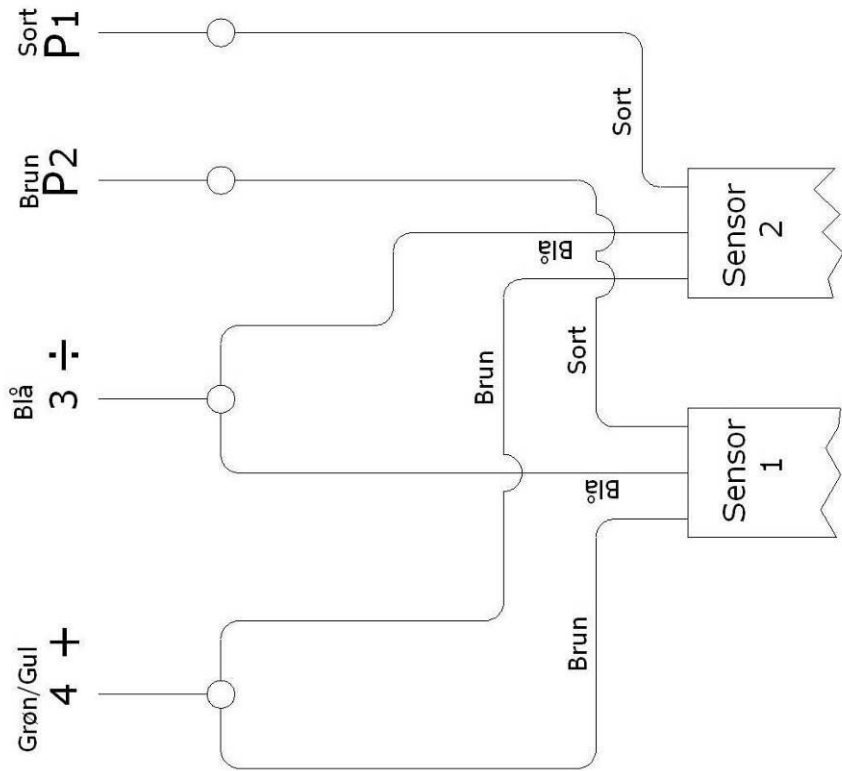

Meterhjul

MCBH4M
Subconn Connector
monteret på
meterhjulet

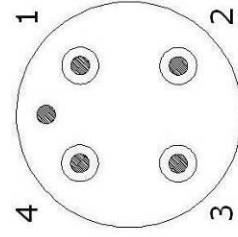

Dato 27-12-2005

KC Denmark - Research Equipment
Lignepolitik, Oceanografi, Hydrobiologi
Tel. +45 86 82 83 47 Fax. +45 86 92 48 50

KC

El-Diagram på induktive
aftastere (Meterhjul)

30.359

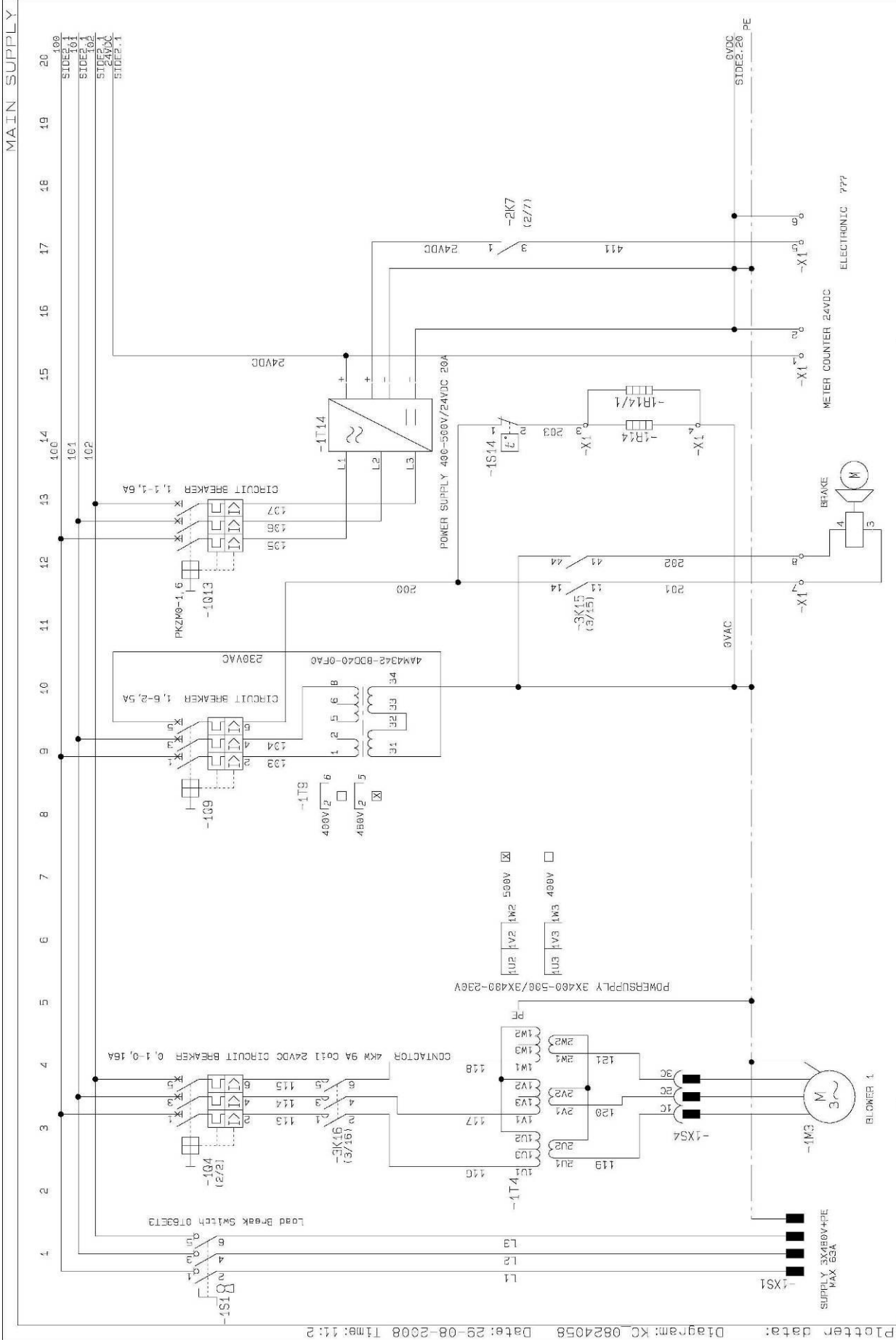

Plotter data:	Diagram: KC_0524058	Date: 29-08-2008	Time: 11:2
MAIN SUPPLY			
Client: KC Denmark Research Equipment	Dwg no: 08 24 058	Plac.: +C1	Page: 1
Project: Winch nr. 40.250	Func.:	Date: 10.06.2008	Page: 1
Prep: PKP	Appr:	Rev: A	

Prinsvej 15
 DK-8500 Silkeborg
 Tlf. 86 82 74 11
 Fax 86 82 74 05

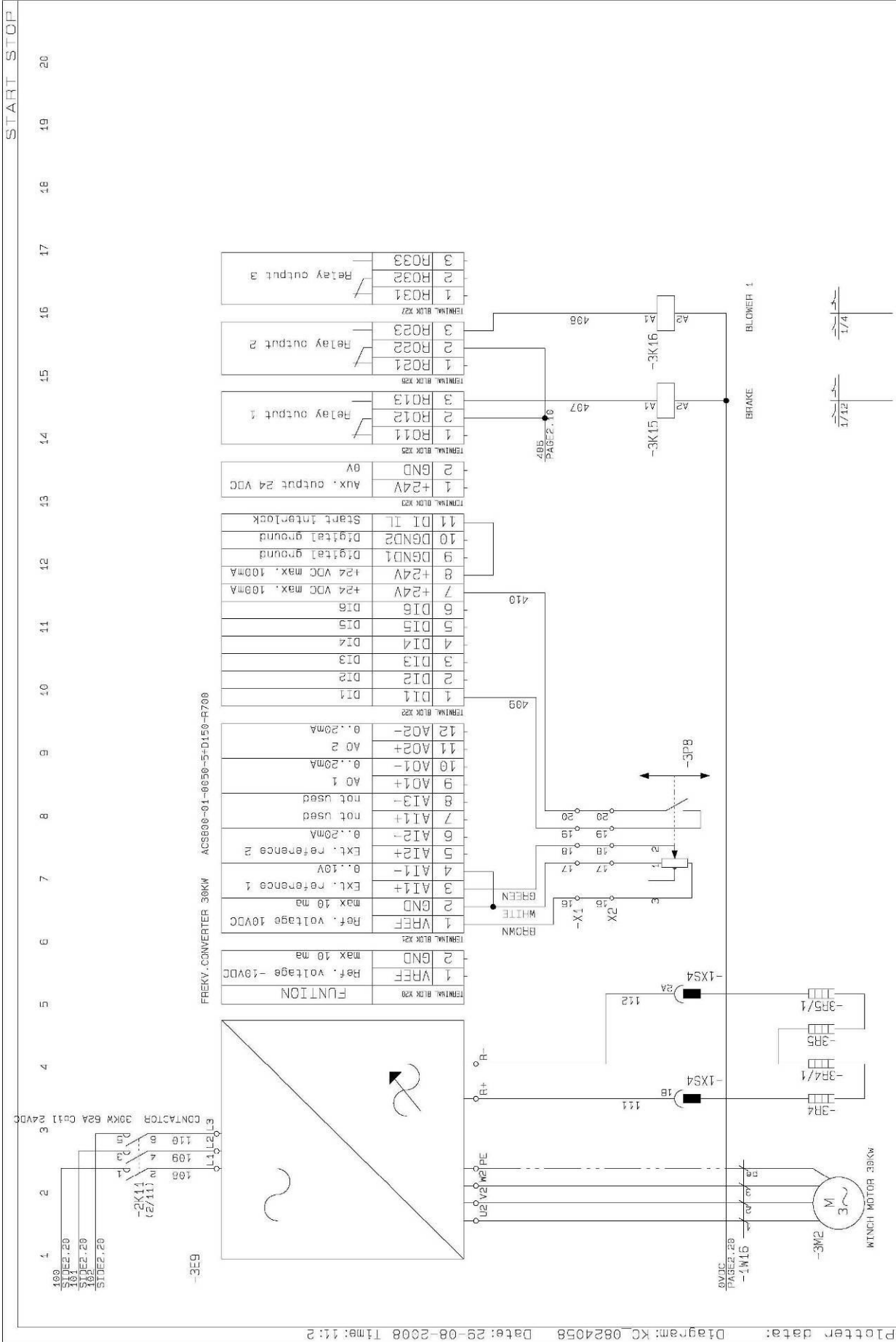

Plotter data: Diagram: KC_0524058 Date: 29-08-2008 Time: 11:2

Client: KC Denmark Research Equipment
 Project: Winch nr. 40.250
 Prep: PKP

Rev: A
 Date: 10.06.2008
 Page: 3

Plac.: +C1

Dwg no: 08 24 058

Func.:
 Date: 10.06.2008
 Page: 3

KC Denmark A/S

Research Equipment
Limnology • Oceanography • Hydrobiology

E-mail: kc@kc-denmark.dk website: <http://www.kc-denmark.dk/>
Holmbladsvej 19 – DK-8600 Silkeborg – Denmark - Tel. +45 86 82 83 47 – Fax +45 86 82 49 50
Bank: Sydbank – S.W.I.F.T. SYBKDK22 IBAN DK5070460000104832 or
VAT no. DK 29 61 96 62